



Model No. 85770-1, -2, -3, -4, -5, -6, 85771, 85772
85780-1, -2, -3, -4, -5, -6, 85781 and 85782
85785-1, -2, -3, -4, -5, -6, -7, -8, -9, -10
SL-V INJECTOR
Series "B"

SINGLE AND MANIFOLD TYPE INJECTORS

for dispensing fluid lubricants and greases not exceeding Lincoln ventmeter viscosity of 600 psi.

SPECIFICATIONS

Minimum operating pressure – 1850 psi [128 bar]

Maximum operating pressure – 6000 psi [413 bar]

Recommended operating pressure – 2500 psi [172 bar]

Maximum vent (recharge) pressure – 1000 psi [69 bar]

Temperature Range - -40°F to 180°F [-40°C - 80°C]

Lubricant output (adjustable):

SL-V - 0.015 to 0.080 cu. in. [0.25 to 1.31 ccm]

SL-V XL - 0.015 to 0.305 cu. in. [0.25 to 5.00 ccm]

Injectors can be mounted in any position and can be used in circuits with SL-1, SL-11, SL-32 and/or SL33 injectors.

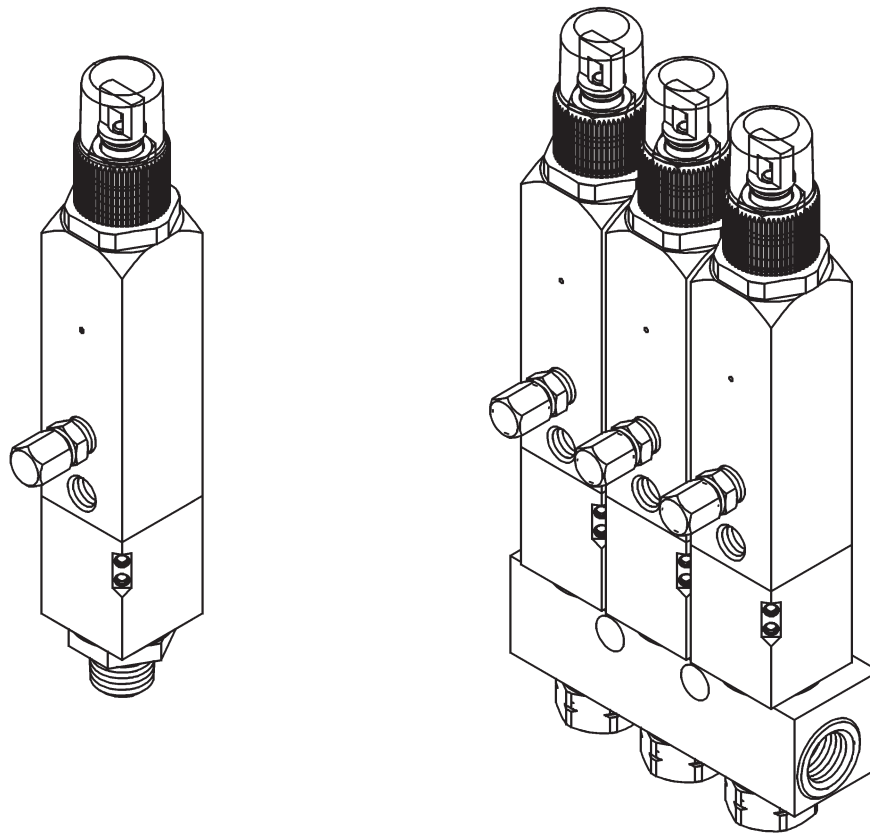

U.S Patent Number 6,705,432, 6,810,998, 6,863,157, 6,986,407
Foreign Patents Pending



One Lincoln Way
St. Louis, MO 63120-1578
Phone +1.314.679.4200
Fax +1.800.424.5359

© Copyright 2007
Printed in USA
Web site:
www.lincolnindustrial.com

Section - **C8**

Page - **301B**

Model No. 85770-1, -2, -3, -4, -5, -6, 85771, 85772
 85780-1, -2, -3, -4, -5, -6, 85781, 85782
 85785-1, -2, -3, -4, -5, -6, -7, -8, -9, -10
 SL-V INJECTOR

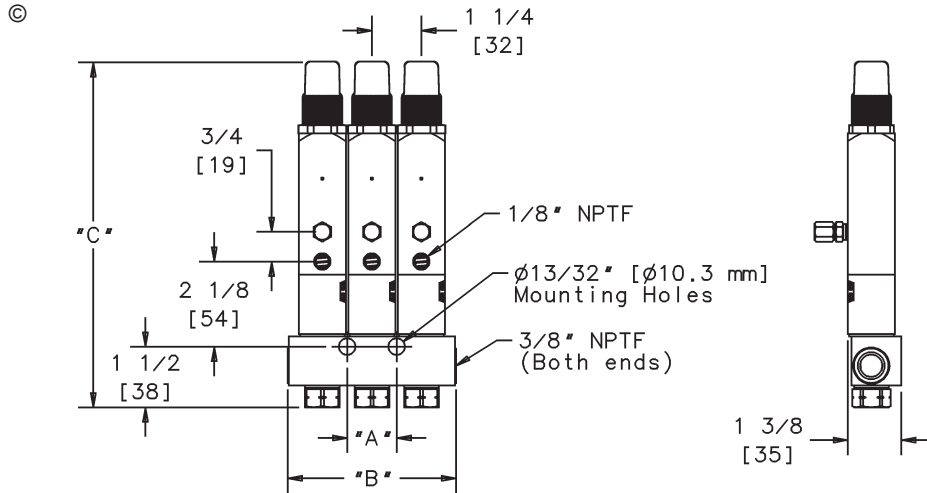

MANIFOLD TYPE INJECTORS

Injector	Model	Type	Dimension "A"		Dimension "B"		Dimension "C"	
			in.	[mm]	in.	[mm]	in.	[mm]
SL-V	85770-1	Single Injector Manifold	*	*	2-1/2	[63.5]	8-3/4	[222]
	85770-2	Two Injector Manifold	*	*	3	[76.2]		
	85770-3	Three Injector Manifold	1-1/4	[31.8]	4-1/4	[108]		
	85770-4	Four Injector Manifold	2-1/2	[63.5]	5-1/2	[140]		
	85770-5	Five Injector Manifold	3-3/4	[95.3]	6-3/4	[171]		
	85770-6	Six Injector Manifold	5	[127]	8	[203]		
	85771	Replacement Injector	N/A		N/A			
SL-V XL	85780-1	Single Injector Manifold	*	*	2-1/2	[63.5]	11-3/16	[284]
	85780-2	Two Injector Manifold	*	*	3	[76.2]		
	85780-3	Three Injector Manifold	1-1/4	[31.8]	4-1/4	[108]		
	85780-4	Four Injector Manifold	2-1/2	[63.5]	5-1/2	[140]		
	85780-5	Five Injector Manifold	3-3/4	[95.3]	6-3/4	[171]		
	85780-6	Six Injector Manifold	5	[127]	8	[203]		
	85781	Replacement Injector	N/A		N/A			

* Single Mounting Hole

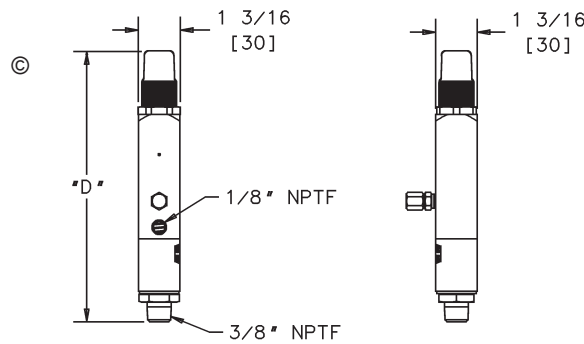

Single Unit Injectors

Injector	Model	Type	Dimension "D"	
			in.	[mm]
SL-V	85772	Single Unit Injector	7-3/4	[191]
SL-V XL	85782	Single Unit Injector	10-3/16	[248]

© Indicates change

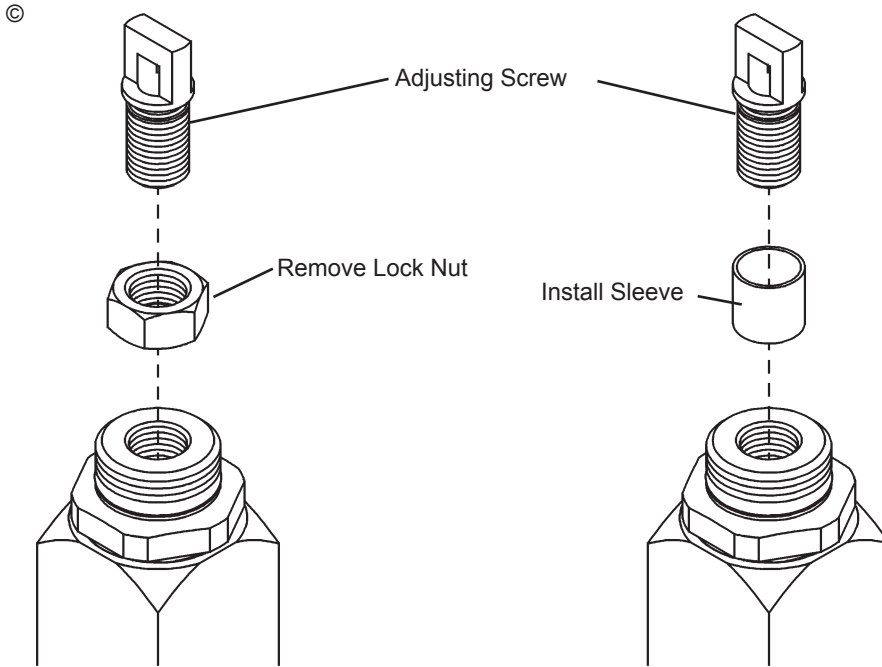

SPECTRUM ADJUSTMENT SYSTEM

The spectrum adjustment system consists of a set of color-coded anodized aluminum sleeves that provide an easy way to adjust the output of the injectors and gives a clear indication of the output setting. This allows for easy system installation and preventative maintenance.

To install a spectrum adjustment sleeve:

Remove and discard the Lock Nut (Item 4), place Sleeve onto Adjusting Screw (Item 3) and tighten.

SL-V SPECTRUM ADJUSTMENT SLEEVES

Part #	Output in ³ (cc)	Ratio from Minimum Output	Ratio from Maximum Output	Sleeve Color
N/A	0.015 (0.25)	1	0.2	N/A
85785-1	0.03 (0.50)	2	0.4	Red
85785-2	0.045 (0.75)	3	0.6	Silver
85785-3	0.06 (1.00)	4	0.8	Gold
85785-4	0.075 (1.25)	5	1.0	Green

SL-V XL SPECTRUM ADJUSTMENT SLEEVES

Part #	Output in ³ (cc)	Ratio from Minimum Output	Ratio from Maximum Output	Sleeve Color
N/A	0.015 (0.25)	1	0.050	N/A
85785-1	0.03 (0.50)	2	0.100	Red
85785-2	0.045 (0.75)	3	0.150	Silver
85785-3	0.06 (1.00)	4	0.200	Gold
85785-4	0.075 (1.25)	5	0.250	Green
85785-5	0.112 (1.87)	7.5	0.375	Black
85785-6	0.15 (2.50)	10	0.500	Purple
85785-7	0.188 (3.12)	12.5	0.625	Blue
85785-8	0.225 (3.75)	15	0.750	Orange
85785-9	0.262 (4.37)	17.5	0.875	Brown
85785-10	0.3 (5.00)	20	1.000	Yellow

Model No. 85770-1, -2, -3, -4, -5, -6, 85771, 85772
 85780-1, -2, -3, -4, -5, -6, 85781, 85782
 85785-1, -2, -3, -4, -5, -6, -7, -8, -9, -10
 SL-V INJECTOR

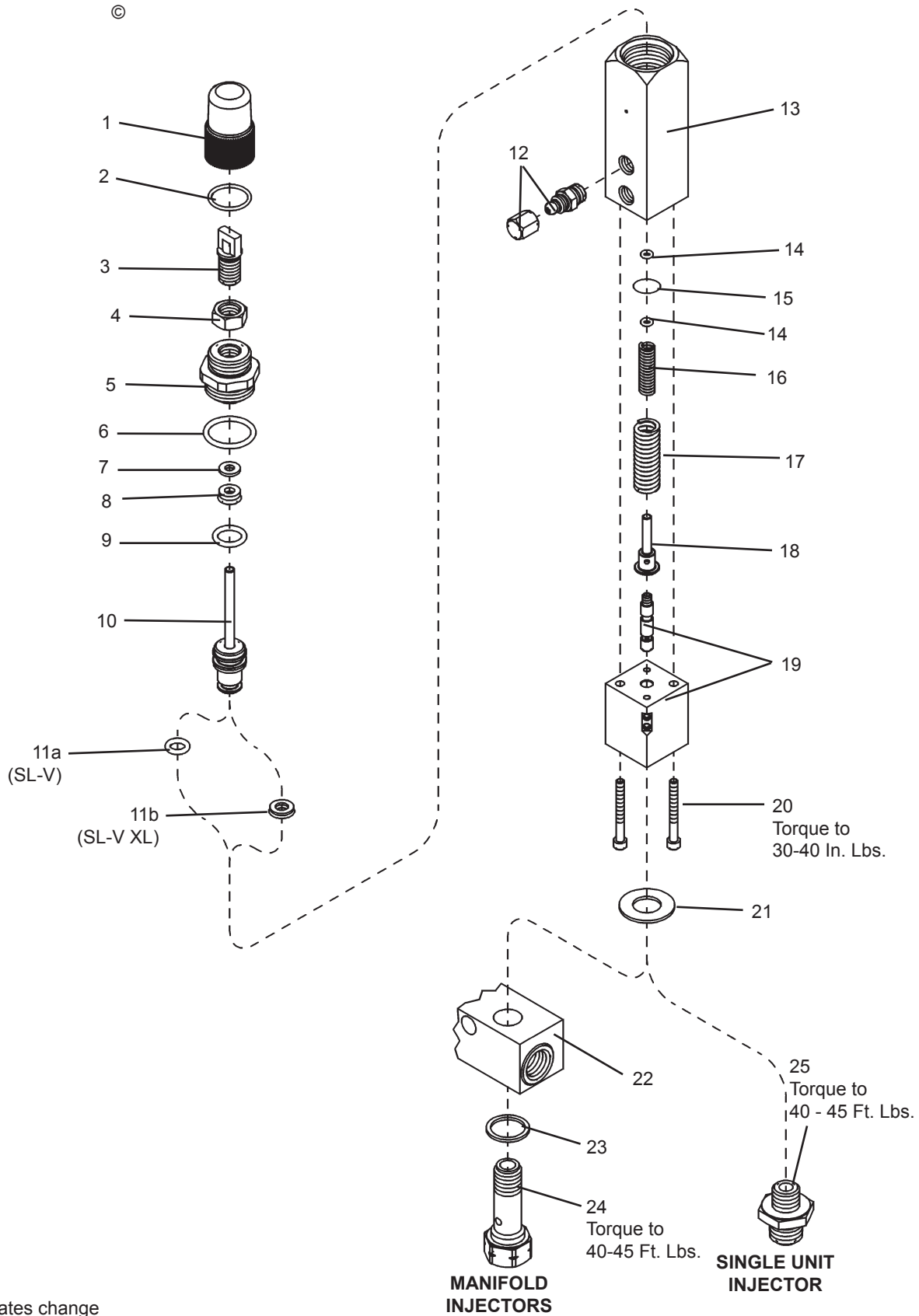

© Indicates change



Model No. 85770-1, -2, -3, -4, -5, -6, 85771, 85772
 85780-1, -2, -3, -4, -5, -6, 85781, 85782
 85785-1, -2, -3, -4, -5, -6, -7, -8, -9, -10
 SL-V INJECTOR

SERVICE PARTS

Item No.	Description	Qty.	Part No.	
			SL-V	SL-V XL
1	Protective Cap (polycarbonate)	1	273088	273089
2	O-ring (nitrile)	1	*	
3	Adjusting Screw	1	272803	272819
4	Lock Nut	1	11624	
5	Piston Stop Plug	1	273090	273091
6	O-ring	1	*	
7	Backup Washer	1	*	
8	U-cup (polyurethane)	1	*	
9	O-ring (polyurethane)	1	*	
10	Piston Assembly	1	273092	273987
11a	O-ring (polyurethane)	1	*	N/A
11b	U-cup (polyurethane)	1	N/A	*
12	Fitting Assembly	1	90471	
13	Injector Body	1	275330©	275331©
14	O-ring (fluorocarbon)	2	*	
15	O-ring (fluorocarbon)	1	*	
16	Spring	1	*	
17	Spring	1	*	
18	Spring Seat	1	272798	
19	Body and Plunger Assy.	1	275332©	
20	Socket Head Screw (8-32 x 1-1/2)	2	272796	
21	Gasket	1	*	
22	Single Injector Manifold	1	12658	
	Two Injector Manifold	1	11962	
	Three Injector Manifold	1	11963	
	Four Injector Manifold	1	11964	
	Five Injector Manifold	1	11965	
	Six Injector Manifold	1	246965	
23	Gasket	1	*	
24	Adapter Bolt	1	273097	
25	Adapter	1	273098	

* Included in 272970 Repair Kit

SL-V Injector Operation

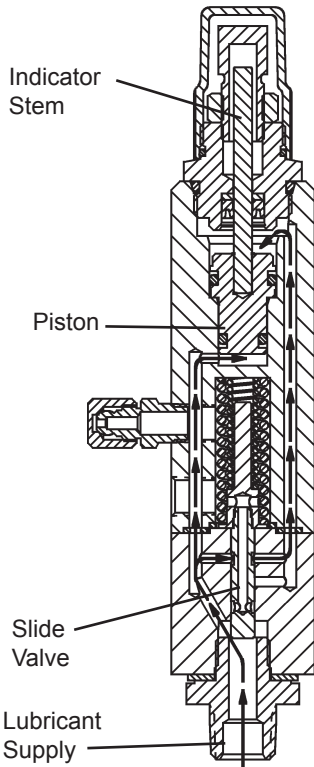

STAGE 1

Stage 1

The injector starts in its normal or rest position. Incoming lubricant is directed through the slide valve to both sides of the piston. The pressure of the incoming lubricant acting on both sides of the piston causes the piston to move downward against the shoulder and fills the measuring chamber. The indicator stem is fully retracted away from the stop of the adjusting screw.

Stage 2

Further increase in pressure causes the slide valve to move against the force of the springs. As the slide valve moves, it closes passage 1 and opens passage 2 to the outlet port. The pressure of the incoming lubricant is now acting only upon the bottom of the piston. The incoming lubricant displaces the piston which forces the lubricant in the measuring chamber to be dispensed through passage 2, through the slide valve and through the outlet port to the lube point.

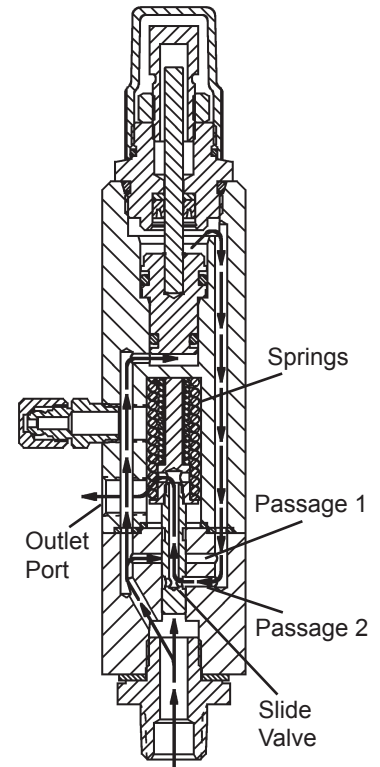

STAGE 2

Stage 3

The piston will dispense lubricant until the indicator stem hits the stop of the adjusting screw. The volume of lubricant dispensed can be adjusted by limiting the travel of the piston. The piston and slide valve remain in this position until the lubricant pressure in the supply line is vented.

Stage 4

As the pressure in the supply line vents to 1000 psig [69 bar], the slide valve moves downward and closes passage 2 and opens passage 1. The lubricant pressure in the supply line is now acting upon both sides of the piston causing it to move downward. As the piston moves downward, a volume of lubricant flows from the underside of the piston, past the slide valve, through passage 1 and to the upper side of the piston. Since the volume on top of the piston is greater than the volume under the piston, an additional volume of lubricant flows from the supply line to the upper side of the piston. This volume of lubricant leaving the supply line causes the pressure to drop very quickly. The piston may or may not fully return to the shoulder, depending upon the volume of lubricant in the supply line. The injector is now ready for the next cycle.

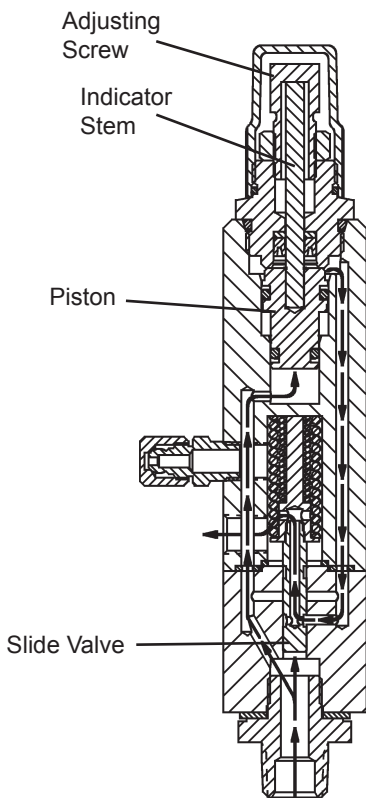

STAGE 3

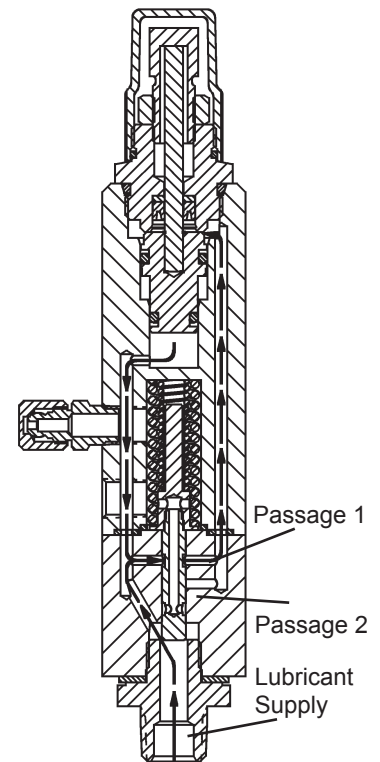

STAGE 4



Model No. 85770-1, -2, -3, -4, -5, -6, 85771, 85772
85780-1, -2, -3, -4, -5, -6, 85781, 85782
85785-1, -2, -3, -4, -5, -6, -7, -8, -9, -10
SL-V INJECTOR

Lincoln Industrial Standard Warranty

LIMITED WARRANTY

Lincoln warrants the equipment manufactured and supplied by Lincoln to be free from defects in material and workmanship for a period of one (1) year following the date of purchase, excluding therefrom any special, extended, or limited warranty published by Lincoln. If equipment is determined to be defective during this warranty period, it will be repaired or replaced, within Lincoln's sole discretion, without charge.

This warranty is conditioned upon the determination of a Lincoln authorized representative that the equipment is defective. To obtain repair or replacement, you must ship the equipment, transportation charges prepaid, with proof of purchase to a Lincoln Authorized Warranty and Service Center within the warranty period.

This warranty is extended to the original retail purchaser only. This warranty does not apply to equipment damaged from accident, overload, abuse, misuse, negligence, faulty installation or abrasive or corrosive material, equipment that has been altered, or equipment repaired by anyone not authorized by Lincoln. This warranty applies only to equipment installed, operated and maintained in strict accordance with the written specifications and recommendations provided by Lincoln or its authorized field personnel.

THIS WARRANTY IS EXCLUSIVE AND IS IN LIEU OF ANY OTHER WARRANTIES, EXPRESS OR IMPLIED, INCLUDING, BUT NOT LIMITED TO, THE WARRANTY OF MERCHANTABILITY OR WARRANTY OF FITNESS FOR A PARTICULAR PURPOSE.

In no event shall Lincoln be liable for incidental or consequential damages. Lincoln's liability for any claim for loss or damages arising out of the sale, resale or use of any Lincoln equipment shall in no event exceed the purchase price. Some jurisdictions do not allow the exclusion or limitation of incidental or consequential damages, therefore the above limitation or exclusion may not apply to you.

This warranty gives you specific legal rights. You may also have other rights that vary by jurisdiction.

Customers not located in the Western Hemisphere or East Asia: Please contact Lincoln GmbH & Co. KG, Walldorf, Germany, for your warranty rights.

Lincoln Industrial Special Limited Warranty

SPECIAL LIMITED 2 YEAR WARRANTY

SL-V Series, Single Injectors-85772, 85782, and Replacement Injectors-85771, 85781

Lincoln warrants the SL-V Injector series to be free from defects in material and workmanship for two (2) years following the date of purchase. If an injector model (single or replacement) is determined to be defective by Lincoln, in its sole discretion, during this warranty period, it will be repaired or replaced, at Lincoln's discretion, without charge.

Lincoln Industrial Contact Information

To find Lincoln Industrial's Nearest Service Center

Call one of the following numbers, you may also use our website

Customer Service - 314-679-4200
Website - www.lincolnindustrial.com

Model No. 85770-1, -2, -3, -4, -5, -6, 85771, 85772
85780-1, -2, -3, -4, -5, -6, 85781, 85782
85785-1, -2, -3, -4, -5, -6, -7, -8, -9, -10
SL-V INJECTOR



**Declaration by the manufacturer as defined by
machinery directive 89/392/EEC Annex IIB**

Herewith we declare that the supplied model of

SL-V

is intended to be incorporated into machinery covered by this
directive and must not be put into service until the machinery
into which it is to be incorporated has been declared in confor-
mity with the provisions of the directive.

Applied harmonized standards in particular:

**EN292 T1/T2
prEN 809**

Paul A. Conley

Paul Conley,
Chief Engineer